



Bosch Packaging Technology, Inc.
Packaging Machines

869 South Knowles Avenue
New Richmond, WI 54017 USA
Phone (715) 246-6511
Fax (715) 246-6539
sales.packaging-nrd@bosch.com
www.boschpackaging.com

Printed in U.S.A.

B-500™
Continuous Band Sealer
Versatile Industrial Sealer

Doboy



Quality. Exceptional Performance. Compact Size.

Industrial Quality

The B-500 provides industrial performance in a compact size. Built to the same high standards as our larger machines the B-500 is at home in wide variety of applications. A full range of options allow you to configure the B-500 to meet your requirements.

Outstanding Features

Heating and Cooling Bars.

The B-500 heat bars are designed to maximize heat transfer and minimize temperature deviation. One pair of 5" long bars provides quality seals on a wide variety of films. The machine also comes equipped with one pair of air cooled high efficiency cool bars. Both the heating and cooling bars have a super hard surface treatment that virtually eliminates surface wear.

Bag Top Control

Full length urethane timing belts grip the bag to assure consistent speed and bag control.

Glass Teflon Sealing Bands

Fiberglass bands provide superior seals on all films and provide a dramatic reduction in maintenance. Sealing bands can be replaced in minutes – with no tools required.

DC Drive

Strong and dependable, speeds on the B-500 can be adjusted from the operator panel. Speeds up to 750" per minute are obtainable dependent upon film gauge and product.

Precision Temperature Control

The B-500 is equipped with precision digital temperature control. Combined with our special thermocouple design the B-500 provides error free performances.

Options

The B-500 is available with a wide variety of options including coders (ink and emboss), bag trimmers, stainless steel construction, counters and integrated conveyors. The B-500 is also available in horizontal or vertical versions.



The machinery shown herein may have had guards removed for illustrative purposes. NEVER operate this machinery without all guards in place and all safety features in original working condition.



The B-500 provides industrial performance in a compact size. Built to the same high standards as our larger machines, the B-500 is at home in wide variety of applications. A full range of options allow you to configure the B-500 to meet your requirements.

Technical Data

Machine Size	
Length	54.5" (140 cm)
Width	24.5" (61 cm) add 6.5" (16 cm) for trimmer
Height (Variable)	48.625" - 58.625" (120 cm- 150 cm) add 5" (13 cm) for casters
Machine Weight	560 lbs. (255 kg)
Production Speed	Up to 750" per min. (dependent on film gauges and types)
Product Range	All heat sealable materials, tube style or gusseted
Sealing Bands	Premium Glass Teflon
Sealing Width	1/4"-standard
Heat Bars	One pair / Imbedded Thermocouples
Compression	Adjustable Pressure Roller
Cooling	One pair of air-cooled bars
Main Drive	DC with speed pot in operator panel
Temperature Control	One Precision Digital Control
Power	110 VAC, 60 Hz, 1 phase, standard

Available Options

- ▶ Coders (Ink or Emboss)
- ▶ Bag Top Trimmer
- ▶ Casters
- ▶ Spare Parts Kit
- ▶ Horizontal Operation
- ▶ Stainless Steel Construction
- ▶ Integrated and Stand Alone Conveyors

Specifications subject to change without notice.

Vertical Format

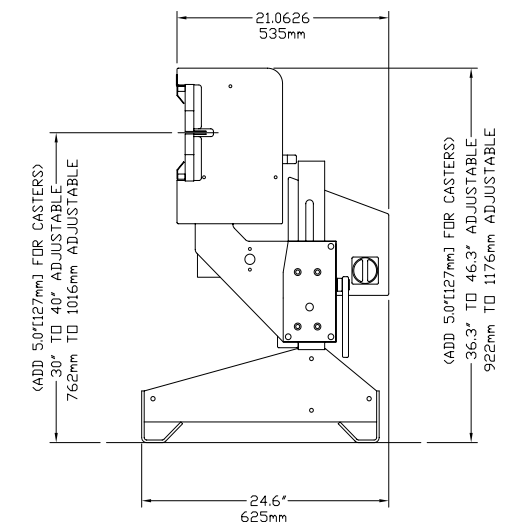

Horizontal Format

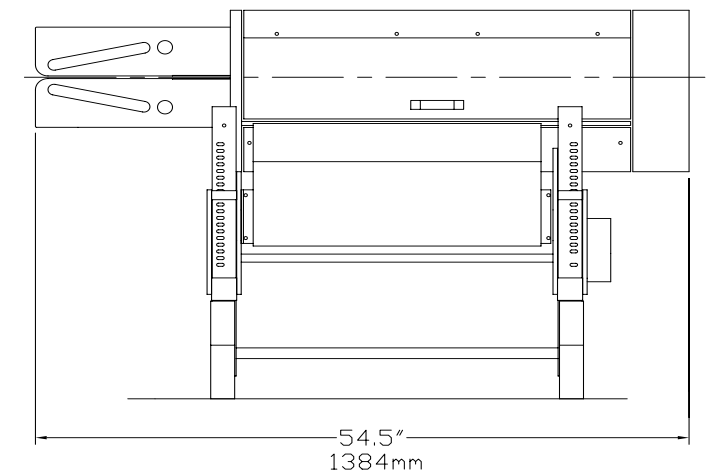

The machinery shown herein may have had guards removed for illustrative purposes. NEVER operate this machinery without all guards in place and all safety features in original working condition.