



Presto Feed Placer

Collating and placing your products into wrapper or cartoner infeed conveyors with the speed and precision of a Delta Robot

Features and Benefits

Fast and Compact Design

- ▶ Up to 400 products/minute
- ▶ 1.3 m x 1.7 m (4.2 ft. x 5.5 ft.) small footprint
- ▶ Simple integration into existing or new lines

Maximum Flexibility

- ▶ Production change-over by 1 person in less than 10 minutes with inexpensive change parts
- ▶ Delicate product handling with vacuum cup end-effectors designed to pick up almost any kind of product
- ▶ Grouping products and rotating the orientation or changing the spacing to match the infeed chain
- ▶ Advanced tracking for precision pick and placement even when products and infeed conveyors are in motion
- ▶ Adapts to changes in production flow with speed control of the wrapper or cartoner when applicable
- ▶ No tools required for change over of end-effector
- ▶ Advance tracking allows use of only one collation chain
- ▶ Automatic recipe back up and restore feature in the event of power failure

Experience

- ▶ Over 1000 parallel axis Delta Robots in several markets in production today
- ▶ In-house design and manufacturing of the 3 major components: Controller, Robot, End-Effector
- ▶ PMMI certified training programs to assure faster return on your investment
- ▶ Extensive parts and technical support by Bosch Packaging Services



Optional HMI swing arm shown.

Color Touch Screen HMI

- ▶ Intuitively menu driven windows to set-up, change-over and run different production configurations

Low Maintenance Robotics

- ▶ Designed for 3 shifts/day operation
- ▶ Fixed position motors and no bending wires for longer life and higher speeds
- ▶ Composite materials for strength and long life
- ▶ No lubricants and no gear boxes above product area
- ▶ Robot arms are collapsible and remountable in 2 minutes
- ▶ Advance tracking eliminates the 2nd collation chain common to most top loading solutions



BOSCH
Invented for life

Presto Feed Placer

Technical Data

Product Range	Minimum	Maximum
Length	50 mm (2")	200 mm (7.9")
Width	15 mm (0.6")	120 mm (4.7")
Height	6 mm (0.24")	60 mm (2.3")
Weight	10 g (0.022 lb)	1 kg (2.2 lb)

Exception: no bare food products

Presto Feed Placer Layout

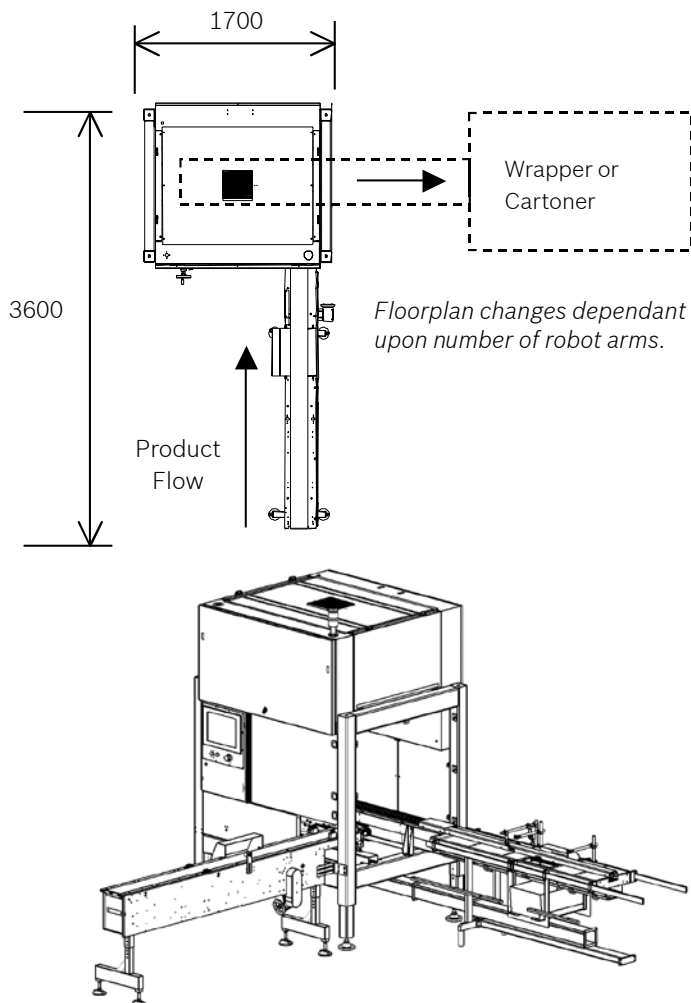

Product Input Requirement

- ▶ Single-stream flow via conveyor belt; minimum spacing between products is 10% of product length

Requirements of Packaging Machine (Cartoner or Wrapper)

- ▶ The infeed must be as narrow as possible and positioned as close to the collator as possible to minimize the robot trajectories and maximize robot performance
- ▶ If the speed control option is selected, the wrapper or cartoner must be capable of allowing the Presto to control its speed based on production flow

Available Options

- ▶ Rotating the orientation of products during the pick and place with a 4th axis on robot
- ▶ Turning products on-edge before feed placing (maximum product width 60 mm)
- ▶ Convenient Dallas key operator authentication with data protection and programmable security levels
- ▶ Packing configuration for 1 or 2 rows in a layer (more rows are possible if products are less than 100 mm long)
- ▶ Speed control of the wrapper or cartoner to adjust to changes in production flow
- ▶ Additional 1 m infeed belt for increased control of spacing between products in the production flow
- ▶ Stainless steel construction
- ▶ HMI swing arm
- ▶ Accumulation shelf to ensure filled infeed flights
- ▶ End-effector off axis motion detection to stop machine
- ▶ Bosch horizontal wrapper machinery for a single source packaging solution

Robot speed is dependent on product size and weight. Not all products that fit in the product range can be packed at the maximum cycle speed. Check with sales support to determine the maximum cycle speed for your application.

Technical information is subject to change without notice.

Bosch Packaging Technology, Inc.

Packaging Machines

869 South Knowles Avenue
New Richmond, WI 54017 USA
Phone (715) 246-6511
Fax (715) 246-6539
sales.packaging-nrd@bosch.com
www.boschpackaging.com

Printed in U.S.A.

© 2008 Bosch Packaging Technology, Inc.

03/09